

- I SAFETY & COMFORT .....2**
- II INTRODUCTION .....4**
- III FIRST TIME SETUP .....5**
- IV STITCHING THE BOOK BLOCK .....6**
- V LOADING STAPLES .....7**
- VI TIPS FOR BETTER BINDING .....8**
- VII TROUBLESHOOTING .....9**
- VIII SPECIFICATIONS .....10**
- IX FCC NOTICE .....11**
- WARRANTY .....12**

Information for Your Reference:

Serial Number: \_\_\_\_\_

Purchase Date: \_\_\_\_\_

## I SAFETY & COMFORT

Please read through this manual before setting up and using your binder.



- Connect all equipment to properly grounded power outlets.
- Do not allow anything to rest on the power cord. Do not locate the Stitcher where persons will step on the cord.
- Place the Stitcher on a flat surface. The Stitcher may not operate properly if it is tilted or at an angle.
- Use only the type of power source indicated on the Stitcher's label on the rear of the machine.
- Do not use a damaged or frayed power cord.
- Unplug this product from the wall outlet before cleaning. Do not use liquid cleaners or aerosol cleaners. Use a damp cloth for cleaning.
- Do not spill food or liquid on the Stitcher.
- Keep your fingers away from the stapling area.
- Except as specifically explained in this guide, do not attempt to service the Stitcher yourself. Opening or removing covers may expose you to dangerous voltage points or other risks. Refer all servicing to service personnel.
- Use of an extension cord with this machine is not recommended or authorized. Users should check building codes and insurance requirements if an extension cord is to be used. Make sure that the total of the ampere ratings of the products plugged into the extension cord does not exceed the extension cord ampere rating, and that the total amperage of all products plugged into the wall outlet does not exceed the outlet rating.
- Do not allow children to use this product, unless under supervision of a responsible adult.

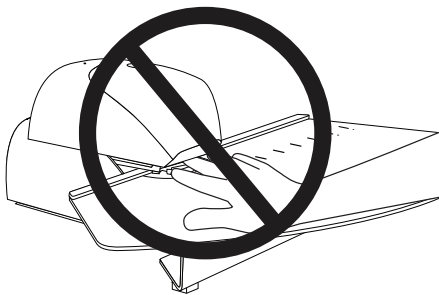

**CAUTION:** Do not insert fingers or anything other than the documents to be stapled into the stapling area.

## I SAFETY & COMFORT (continued)

In recent years, medical attention on occupational injuries has identified common, seemingly harmless activities as potential causes of a wide range of problems collectively known as Repetitive Stress Injuries or Cumulative Trauma Disorders. It is now recognized that any repetitive motion may contribute to these health problems. Depending on how it is used, the prolonged or repetitive use of almost any machine might have a potential for discomfort or injury. As a user of this Stitcher, you might also be at risk.

The most commonly accepted causes of this type of disorder are repeated, forceful actions, usually in an awkward position or posture, without sufficient rest to allow the body to recover. These repetitive actions may cause nerves, tendons, ligaments, and other soft body parts to become irritated and inflamed.

By paying attention to the way you perform your work, and do other activities, you can identify the behaviors that could put you at risk. The precautions outlined below are examples you can take to help reduce the likelihood of developing these problems and work more comfortably with your new Stitcher. Keep in mind, however, that these are only suggestions. Comfort is personal and only you may be able to judge what works best for you.

- You may find that your body will be most comfortable and relaxed with the Stitcher placed directly in front of you. The Stitcher and your supplies should be within easy reach —avoid excessive stretching.
- The Stitcher may be used in either a standing or seated position. If you are standing, make sure that the work surface height that the Stitcher is on does not require you to bend over in a way that would strain your back or arms.
- If you are seated, adjust the height of your chair to your table so your body is naturally aligned and make sure you have adequate legroom. Stay relaxed and relatively upright. Don't force yourself into an uncomfortable position.
- Do not bend your wrists unnaturally during use.
- Don't stay in one position for too long. Try changing hands and varying your posture.
- Take breaks. Frequent short breaks are probably better than a few long ones.

Many factors go into creating a comfortable workspace, including proper placement and adjustment of furniture and equipment. A thorough work site analysis by a qualified expert is important in order to reduce the risk of repetitive motion injuries. If you experience pain, throbbing, aching, tingling, stiffness, a burning sensation, swelling, numbness, or weakness in your wrists, hands, arms or legs, see your physician immediately.

**DO NOT IGNORE THESE WARNING SIGNS.** Even if symptoms occur when you are not using the Stitcher, they can be associated with painful and sometimes permanently disabling injuries or disorders of the nerves, muscles, tendons, or other parts of the body. These symptoms could mean that you are developing a repetitive stress injury that requires prompt medical attention. For more detailed information, consult your doctor.

## II INTRODUCTION

Congratulations on the purchase of your new Powis S52 Stitcher. Like all our equipment, this machine was carefully assembled and tested prior to packing. You will find it fast and easy to use. The Powis S52 Stitcher was designed to work with the Fastback 8x binder and the Fastback Hardcover Guide. It is an important component of the Powis Studio Photobook System.

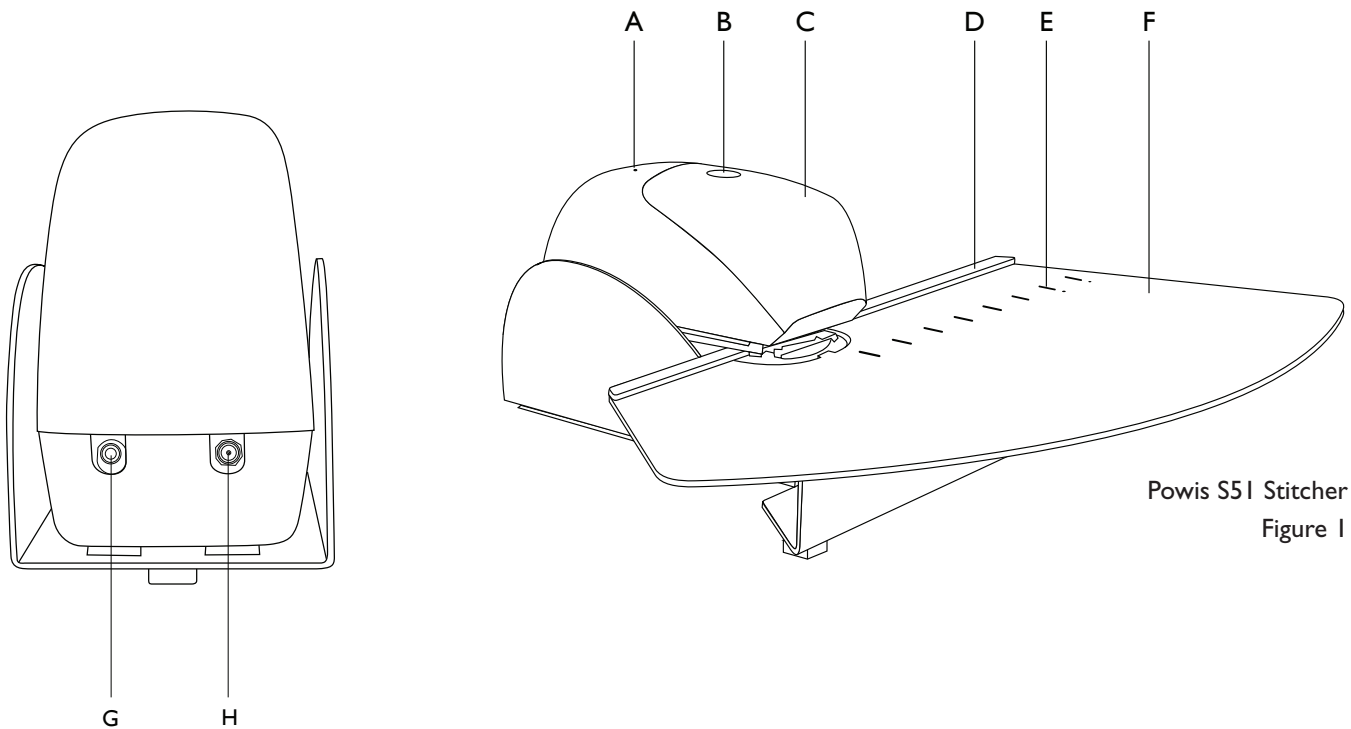

Powis S51 Stitcher  
Figure 1

Staple Loading Mechanism  
Figure 2

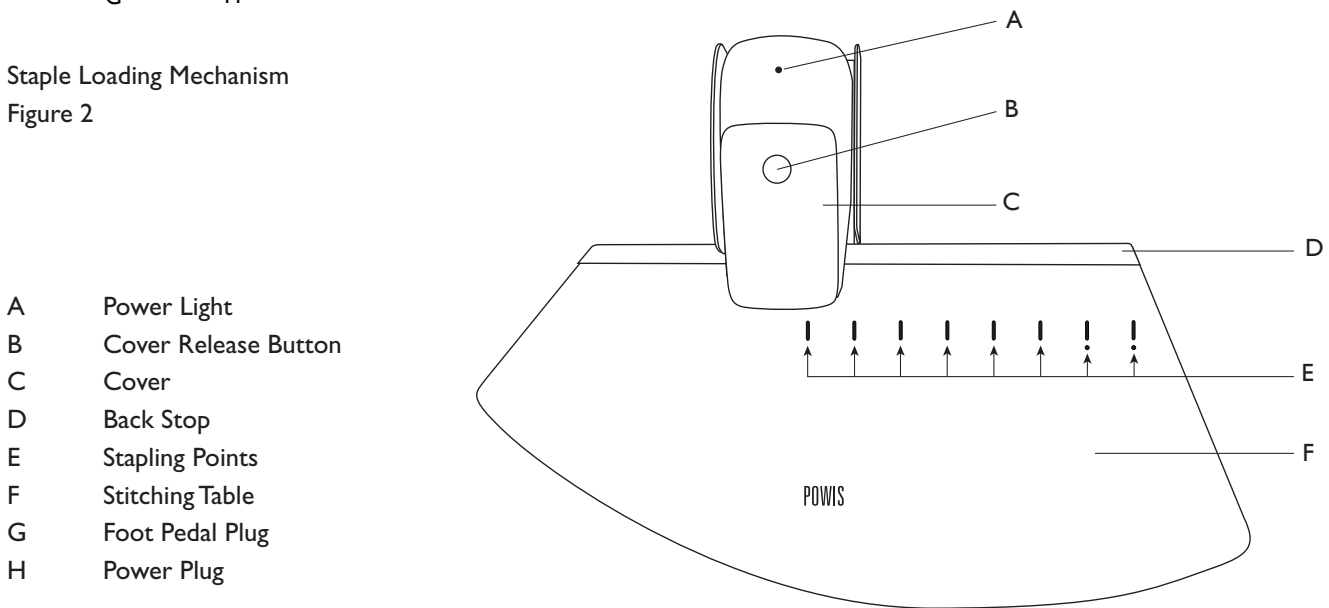

- A Power Light
- B Cover Release Button
- C Cover
- D Back Stop
- E Stapling Points
- F Stitching Table
- G Foot Pedal Plug
- H Power Plug

Stitching Table  
Figure 3

### III FIRST TIME SETUP

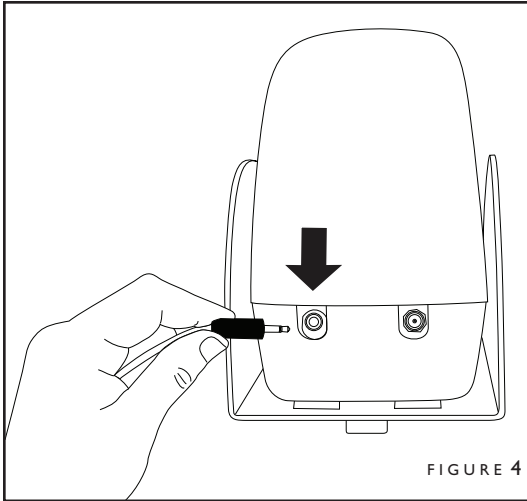

#### A. What's Included Inside the Box

- The Powis S52 Stitcher
- Accessory Box, which contains:
  - 2 User Manuals
  - Foot Pedal
  - 1 Staple Cassette
  - Power supply adapter

If any items are damaged or missing, contact Powis Parker dealer immediately.

#### B. Set Up and Plug in Foot Pedal

Place the Powis Stitcher on a flat, unobstructed work surface. Plug the Foot Pedal into the socket at the rear of the Stitcher (see Figure 4).

**IMPORTANT:** Foot pedal must be plugged in *before* the power Adapter.

#### C. Plug In Power Adapter

Plug the adapter into the wall socket into the wall socket, then plug the power adapter into the Stitcher (See Figure 5). The LED on top of the Stitcher will light up green, indicating that it the Stitcher is on.

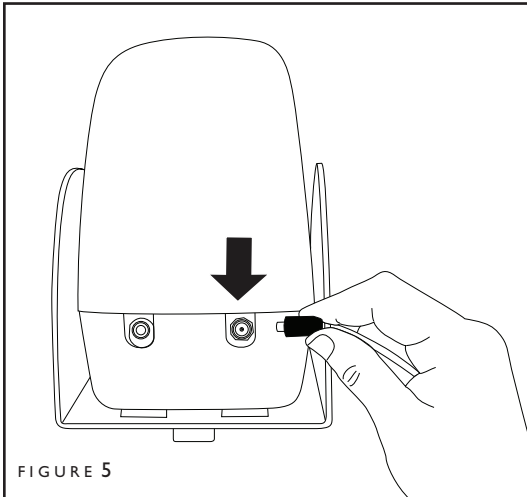

## IV STITCHING THE BOOK BLOCK

Before using the Stitcher, bind the book block with the Fastback 8x. For more information on binding see the Fastback 9 manual or the Studio Binding System Quick Start Guide.

### Using the Stitcher

The stitching table is designed to make binding book blocks fast and easy to do. Stapling points for A4, A5, 11" and 8½" spine lengths are indicated on the stitching table (Figure 6).

1. Place the book block on the stitching table with the spine edge pressed against the back stop (Figure 7).
2. Press the foot pedal (Figure 8).
3. Starting from the left and moving right, line the bound edge of the book block up with the first stapling point on the stitching table (Figures 6).
4. Move the book block to the next stapling point and press the foot pedal again. Continue this process until the book block is completely stapled across the binding edge (figure 9).

The book block is now ready to add the cover:

**HINT:** To give your book a more polished final appearance, you may also add headbands. See the Fastback Hardcover Guide manual for more information.

**CAUTION:** Do not activate the foot pedal without paper—jamming will occur. If the Stitcher does jam, please refer to the Troubleshooting section for assistance.

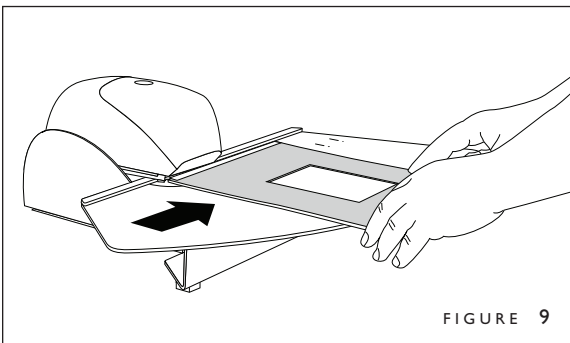
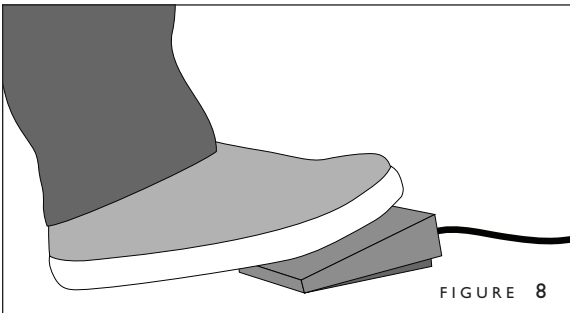
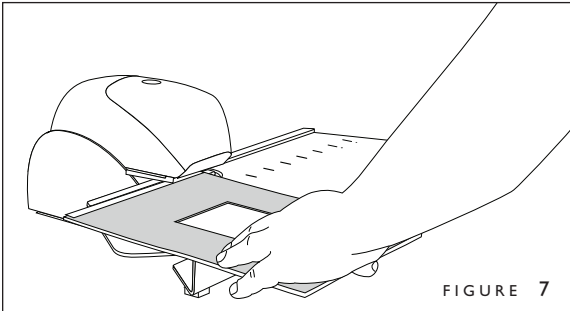
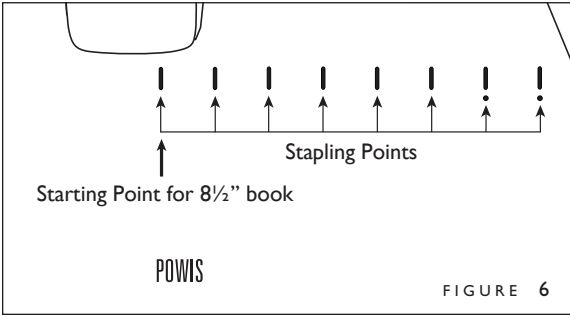

## V | **LOADING STAPLES**

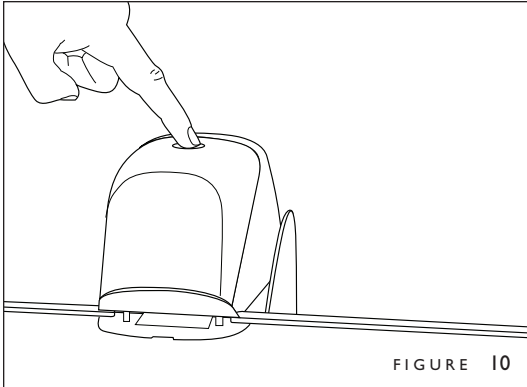

The power light on the top of the Sticher (see Figure 1) turns from green to red when the staple cassette is down to 19 remaining staples.

**IMPORTANT:** Use only original Rapid 5080 staple cassettes. The wrong type of staples can damage the unit or may result in jamming and badly stapled book blocks.

1. Press Release Button on top of the unit to remove the Cover (Figure 10).

Inside you will see the Staple Cassette (Figure 11).

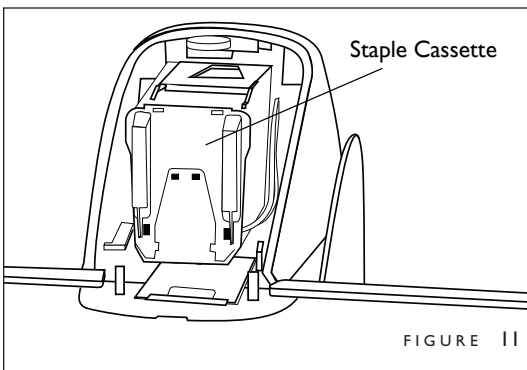

2. Grasp the cassette on both side and pull straight out horizontally (Figure 12).
3. Replace the cassette by inserting the new cassette straight into the Sticher until the cassette clamps in place (Figure 13).
4. Snap the Cover back into place. The Power Light on the top of the Sticher should now appear green.

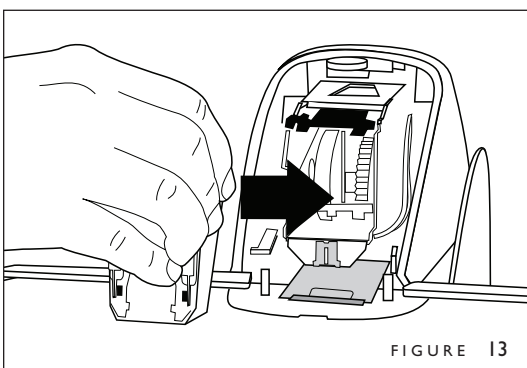
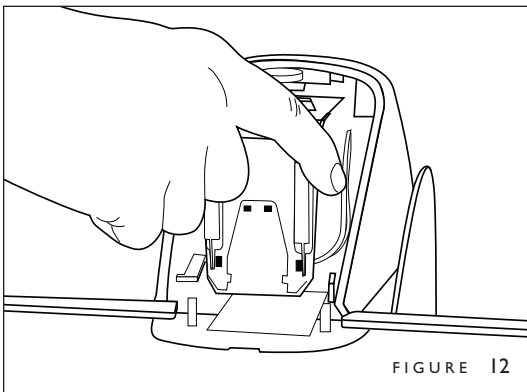

## VI | TIPS FOR BETTER BINDING

---

- All paper has a grain — it is a result of the fibers that make up the paper. The grain of the paper should run parallel to the binding edge of the document. If the grain runs parallel to the long side of the sheet, the paper is “grain long”. When the grain runs parallel to the short side of the paper, it is “grain short”.

A sheet of paper will naturally flex more easily along the direction of its grain. Most copy papers are grain long, so you should not have any problems with the bind. Grain long paper will give you the best bind. Occasionally you may find papers that are grain short, so we recommend you test unfamiliar papers before binding large numbers of documents.

- How many sheets of paper the Powis Stitcher can bind depends on the weight and the surface density of the paper. Always run a test sample before proceeding.
- How many sheets of paper the Powis Stitcher can bind depends on the weight and the surface density of the paper. Always run a test sample before proceeding.

## VII TROUBLESHOOTING

### Removing jammed staples

1. Remove Cover and cassette (see page 7).
2. Remove jammed staple(s) from the cassette. Difficult jams may require needle-nosed pliers to remove. Be careful not to damage the cassette when removing jams with pliers or similar tools.
3. Depress the magazine release on the front of the insert stapler and pull out the magazine.

**IMPORTANT:** Make sure that the stapler die has been returned to the down position before using the stapler (Fig. 14).

### Stitcher will not operate

Check that:

1. The unit is receiving current (the light on the top of the Stitcher should be green).
2. The cover is firmly snapped in place.
3. The foot control is properly plugged in.

For further information and troubleshooting, please consult the Rapid 5050/508e manual included with this unit.

If the problems remain, return the unit to your supplier or to Powis Tech Support. Do not use a machine with a faulty connecting cable or plug.

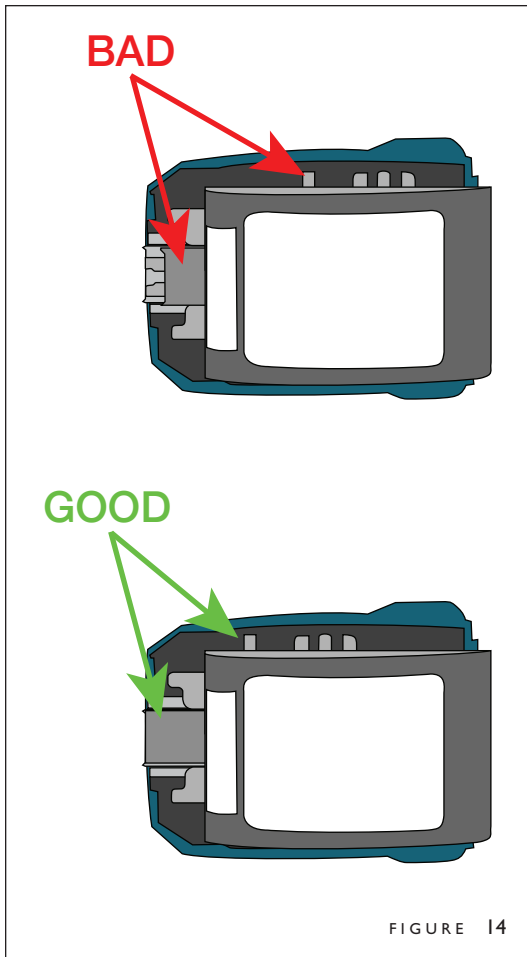

## VIII SPECIFICATIONS

---

<b>Power Requirements:</b>	S52: 120V~ 50-60 Hz, 0.5 Amps
<b>Recommended Operating Temperature and Humidity:</b>	15 to 35 degrees (C), 59 to 95 degrees (F) Humidity Range: 5 to 80% RH noncondensing
<b>Weight:</b>	12.5 lbs
<b>Dimensions:</b>	23.5"W x 6.75" H x 17.5" D
<b>Bind Capacity:</b>	Dependent on paper thickness and density.

- Modifications made to the product, unless expressly approved by Powis Parker, could void the user's authority to operate the equipment.

Note: This equipment has been tested and found to comply with the limits for a Class B digital device, pursuant to Part 15 of the FCC Rules. These limits are designed to provide reasonable protection against harmful interference in a residential installation. This equipment generates, uses, and can radiate radio frequency energy and, if not installed and used in accordance with the instruction, may cause harmful interference to radio communications. However, there is no guarantee that interference will not occur in a particular installation. If this equipment does cause harmful interference to radio or television reception, which can be determined by turning the equipment off and on, the user is encouraged to try and correct the interference by one or more of the following measures:

- Reorient or locate the receiving antenna.
- Increase the separation between the equipment and receiver.
- Connect the equipment into an outlet on a circuit from that to which the receiver is connected.
- Consult the dealer or an experienced radio/TV technician for help.

#### DECLARATION OF CONFORMITY

We, Powis Parker, Incorporated  
775 Heinz Avenue  
Berkeley, CA 94710 U.S.A  
1-800-321-2463

declare under our sole responsibility that the product  
Powis S51 Stitcher  
complies with Part 15 of FCC Rules.

Operation is subject to the following two conditions: (1) this device may not cause harmful interference, and (2) this device must accept any interference received, including interference that may cause undesired operation.

- Binder does not contain any user serviceable parts. Return unit to an authorized Powis Parker representative for repair or service.

#### POWIS PARKER PART NUMBERS FOR YOUR REFERENCE:

204988	POWIS S51 STITCHER USER'S MANUAL
204986	FOOT PEDAL
204984	CRIMPING TOOL
204982	STAPLES
204985	TORX SCREWDRIVER

## **COPYRIGHT INFORMATION**

This document contains proprietary and confidential information of Powis Parker Incorporated (PPI).

Copyright © Powis Parker Incorporated 2007

All Rights Reserved.

No part of this document may be photocopied, reproduced in any form, or translated into another language without prior written consent of PPI, except as allowed under the copyright laws.

## **WARRANTY**

One (1) Year from date of purchase.

The information contained in this document is subject to change without notice.

PPI makes no warranty of any kind with respect to this information. PPI specifically disclaims the implied warranty of merchantability and fitness for a particular purpose.

PPI shall not be liable for any direct, indirect, incidental, consequential, or other damage alleged in connection with the furnishing or use of this information.

## **NOTICE**

Changes are periodically made to this document. Revisions, changes, any technical inaccuracies, and typographical errors will be corrected in any subsequent editions.